

The Triple Line Lifter-6000 is an insulated crane attachment used to support up to three energized lines.

The TLL-6000

- Maximum capacity of 6000 pounds per phase with a total capacity of 18000 pounds.
- Own or lease a unit and use it on your own schedule.
- Faster set up time.
- Radio remote provides the crew in the bucket with complete control of the unit's functions and avoids having to relay desired movements to ground personnel working the controls.
- Ability to capture phases and neutrals/statics with the same crane. Reducing the equipment needed at a job site and further eliminates shutdown of transmission lines for maintenance.
- One base unit can fit multiple crane models with additional adapters and load charts.



FEATURES

- Hydraulic articulation, extension & retraction
- Quick attach insulators & wire holders
- Insulators are lab tested (retest every 2 years)
- Operation, Maintenance and Parts manuals
- Custom load charts for your crane model(s)
- Vertical and horizontal line construction
- High strength steel and fiberglass fabrication
- Holding valves on all cylinders
- Manual override control valve
- Handheld radio remote control
- Installed at ground level

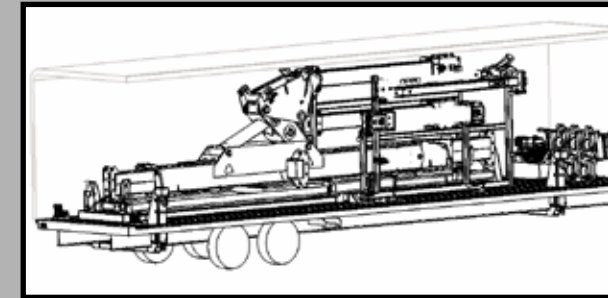

Hydraulic Power Unit

- 3000 psi and 15 gpm
- Hose reel with power return
- Gasoline engine 40HP / electric start
- 130 ft. of nonconductive hose (2)
- Fork pockets, 4 lifting rings with rigging



Transportation Trailer

- Lift rigging and down points
- Racks for:
 - Insulators, wire holders & pins
- 4 corner jacks to level skid to crane
- Steps/handrails to access boom tip for installation
- Tilt to raise unit to pin to crane

SPECIFICATIONS

Voltage (#) Phases 400 kV (3) phases	Capacity per phase 6000 lb (2722 kg)/18000 (8165 kg) total
Total unit weight (Approx.) TLL-6000 TLL-6000 w/(1) static arm TLL-6000 w/(2) static arms	14000 lb (6350 kg) 14650 lb (6645 kg) 15300 lb (6940 kg)
Max. Phase Spacing Outside to Outside Center to Outside	62' (18898 mm) 31' (9449 mm)
Min. Phase Spacing Outside to Outside Center to Outside	32' (9754 mm) 16' (4877 mm)
Horizontal Configuration Max Load per Phase	6000 lb (2722 kg) vertical load 1500 lb (680 kg) side load
Vertical Configuration Max Load per Phase	6000 lb (2722 kg) vertical load 1500 lb (680 kg) side load
Maximum Load per Static Arm Wire Holder	600 lb (272 kg) vertical load 250 lb (113 kg) side load
Insulator	Fiberglass
Hydraulic	Yes
Mounting	Minimum 300 Ton Crane

CONFIGURATIONS

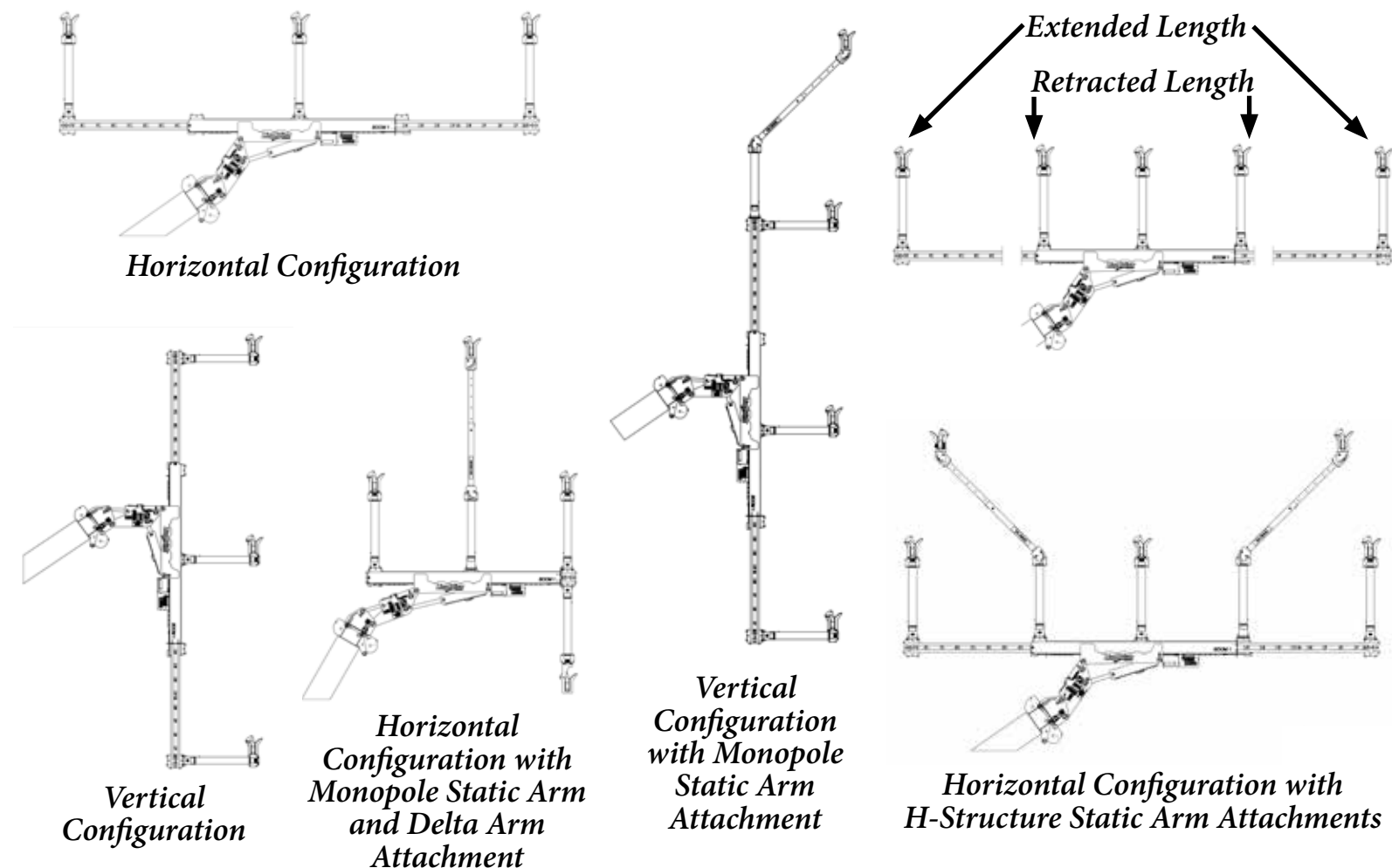

OPTIONS

- Adapters made for specific cranes
- Adjustable static arms for vertical or horizontal configuration
- Swing gate wire holders
- Vertical/horizontal bundle wire holders
- Product operational by hydraulics
- Storage box for additional insulators
- Fully covered skid on trailer

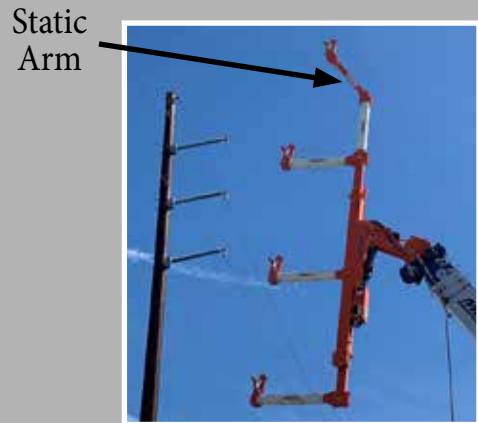

Swing Gate Wire Holder

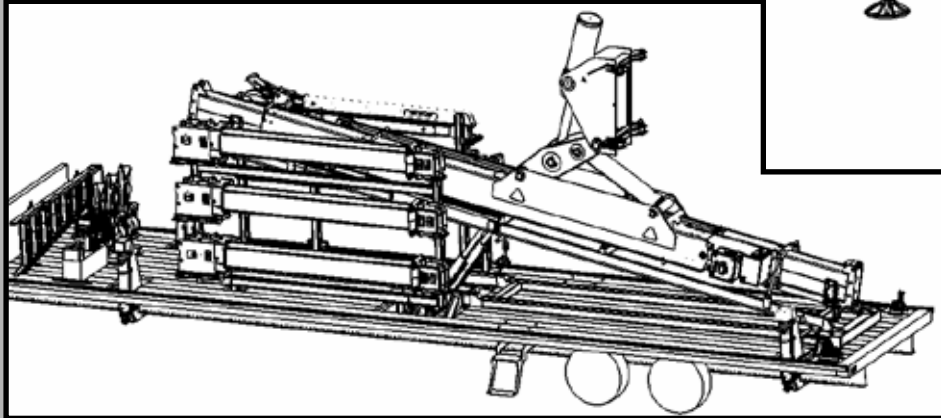
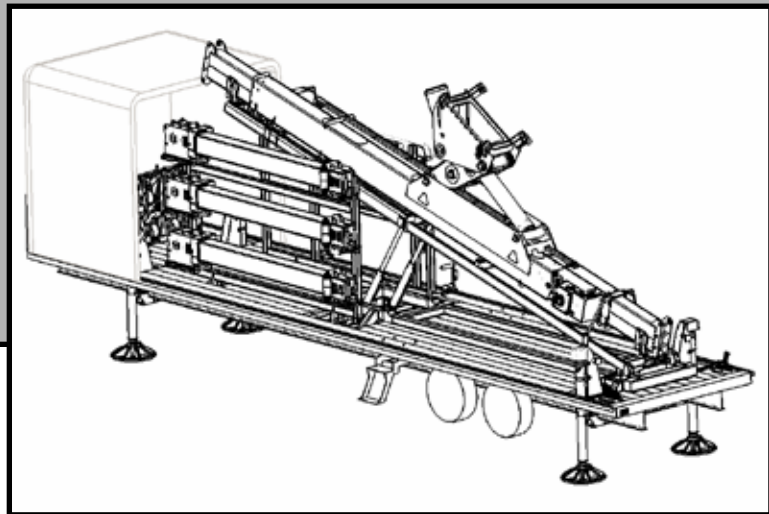

**INSPIRED,
TESTED,
AND TRUSTED
BY LINeworkERS**



LINEWISE

Triple Line Lifter-6000



Material and specifications are subject to change without notice. Units in photos may include optional features. Contact a LineWise representative for available options. LineWise® and the LineWise logo are registered trademarks of Fritel & Associates, LLC and may not be used without permission. © 2025 Diversified Product Development All Rights Reserved.