

Customer: _____
 Contact Name: _____
 E-mail: _____
 Phone #: _____

For any questions or concerns, please call (254) 757-1177 and ask for our Sales Department or email sales@line-wise.com

1

Base Unit

Cover Assembly (73781)

Skid Assembly (73681)

70000

or

Cover Assembly (73781-18)

Skid Assembly (73681)

70000-18

Limited range due to crane

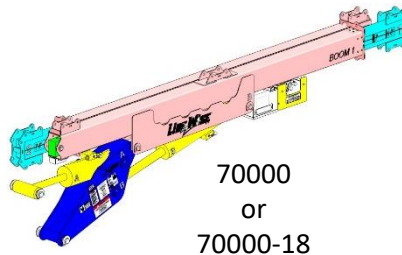

70000
or
70000-18

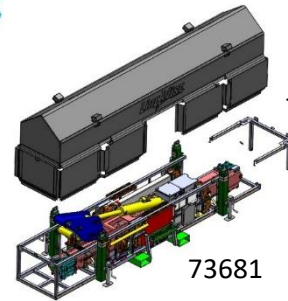

73781
or
73781-18

73681

2

Adapter

(Included with base unit)

—Crane Information—

Crane Make and Model:

Crane Serial #:

Able to provide Load Charts?:

Adapter # if in List

Must be able to provide pictures of boom tip, serial number plate, and load chart

Crane Adapters we have:

70030-01 – National, NBT55-128 / NBT45-161 / NBT50-128

70030-02 – Altec, AC40-152S

70030-03 – Manitex, 30124C / 35124C / 38124S / 40124S

70030-04 – Manitex, 50155 / 50128 / 50110 / 5096

70030-05 – Manitex, 40127 / 45127 / 40142 / 45142

70030-06 – Manitex, 30-112S / 30-102C

70030-07 – National, NBT45-142 / NBT40-127

70030-08 – Terex, BT70100

70030-09 – Liebherr, LTM 1050-3.1 (requires 70000-18)

70030-10 – Altec, AC26-103S / AC30-103S

70030-11 – National, 14127A / 14127H

70030-12 – National, 1195

70030-13 – Altec, AC38-103S / AC38-127S / AC45-127S

70030-14 – Elliott, 40142

70030-15 – National, NBT60128 / NBT50L / NTC50L / NBT55L / NTC55L / NBT60L / NTC60L

70030-16 – Elliott, D86 / D105 / D115

70030-17 – Grove, GMK 3060 (requires 70000-18)

70030-18 – Liebherr, LMT 1055-3.2 (requires 70000-18)

70030-19 – Altec, AC40E-152S

3

Choose HPU

- Gas HPU (73560) (Included with base unit)
- Cold Weather Package (73562) additional includes a tank heater and a enclosed skid

73560

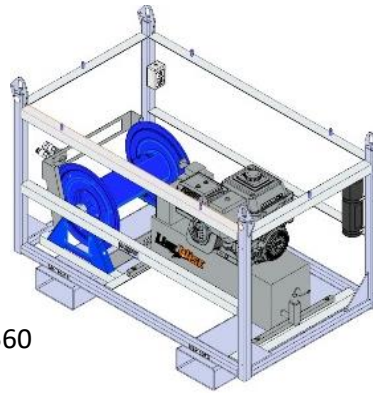

73562

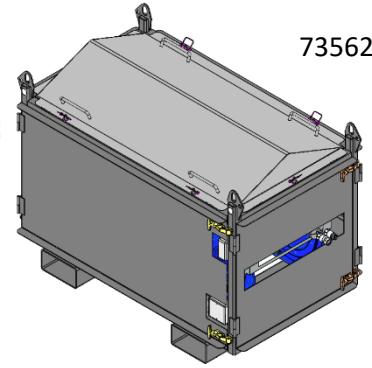

4

Choose Insulators

(Each Unit requires a set of insulators. Capacity will vary.)
Clear span shown in parentheses
Includes dielectric testing and covers

70107 with standard wire holder

- 69 / 115 kV Sealed Fiberglass set of 3 (40 ½")
70107-115
- 138 kV Sealed Fiberglass set of 3 (47 ¼")
70107-138
- 161 kV Sealed Fiberglass set of 3 (55")
70107-161
- 230 kV Sealed Fiberglass set of 3 (74")
70107-230
- 230 kV Sealed Fiberglass set of 2 (74")
70107-230-2

78770 with optional SGWH

- 69 / 115 kV Sealed Fiberglass set of 3 (40 ½")
78770-115
- 138 kV Sealed Fiberglass set of 3 (47 ¼")
78770-138
- 161 kV Sealed Fiberglass set of 3 (55")
78770-161
- 230 kV Sealed Fiberglass set of 3 (74")
78770-230
- 230 kV Sealed Fiberglass set of 2 (74")
78770-230-2

Standard Wire Holder

No Corona Ring

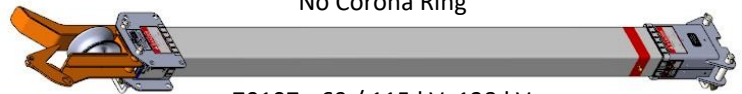

70107 - 69 / 115 kV, 138 kV

With Corona Ring

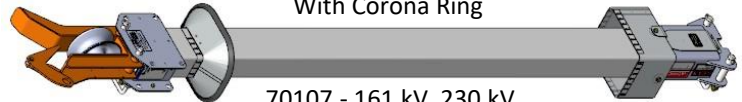

70107 - 161 kV, 230 kV

Swing Gate Wire Holder

No Corona Ring

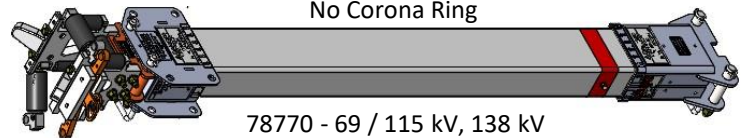

78770 - 69 / 115 kV, 138 kV

With Corona Ring

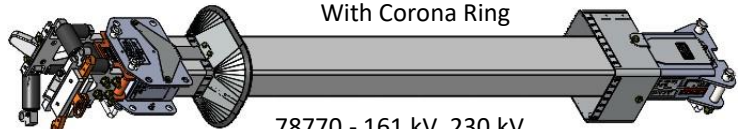

78770 - 161 kV, 230 kV

5

Additional Information / Questions

6

Available Options

(Add Quantity Desired)

Some Options might change capacity

QTY: ___ *Swing Gate Wire Holder (76383)*

—Extra Insulator package—

QTY: ___ *69/115 kV Insulator Package (70105-115)*

QTY: ___ *138 kV Insulator Package (70105-138)*

QTY: ___ *161 kV Insulator Package (70105-161)*

QTY: ___ *230 kV Insulator Package (70105-230)*

—Extra SGWH Insulator package—

QTY: ___ *69/115 kV SGWH Insulator Package (76386-115)*

QTY: ___ *138 kV SGWH Insulator Package (76386-138)*

QTY: ___ *161 kV SGWH Insulator Package (76386-161)*

QTY: ___ *230 kV SGWH Insulator Package (76386-230)*

—Insulator with Hardware—

QTY: ___ *69/115 kV Insulator with Hardware (70104-115)*

QTY: ___ *138 kV Insulator with Hardware (70104-138)*

QTY: ___ *161 kV Insulator with Hardware (70104-161)*

QTY: ___ *230 kV Insulator with Hardware (70104-230)*

—Extra Insulator Covers—

QTY: ___ *69/115 kV Cover (70106-115)*

QTY: ___ *138 kV Cover (70106-138)*

QTY: ___ *161 kV Cover (70106-161)*

QTY: ___ *230 kV Cover (70106-230)*

—Components—

QTY: ___ *70570 (Wire Holder)*

QTY: ___ *70001 (Double Pin for Wire Holder)*

QTY: ___ *70006 (Double Pin for Insulator)*

QTY: ___ *65862 (Linch Pin)*

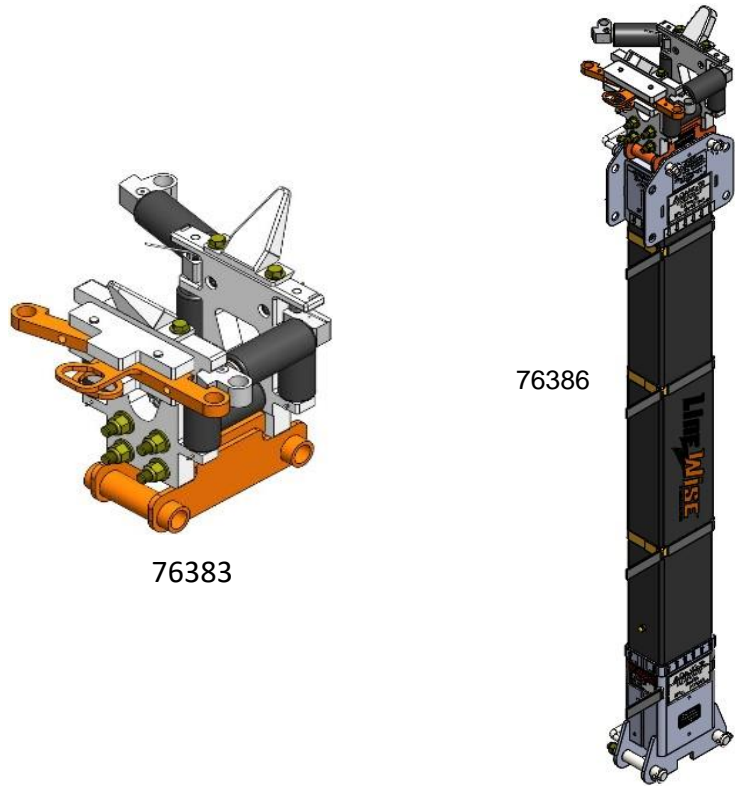

76383

76386

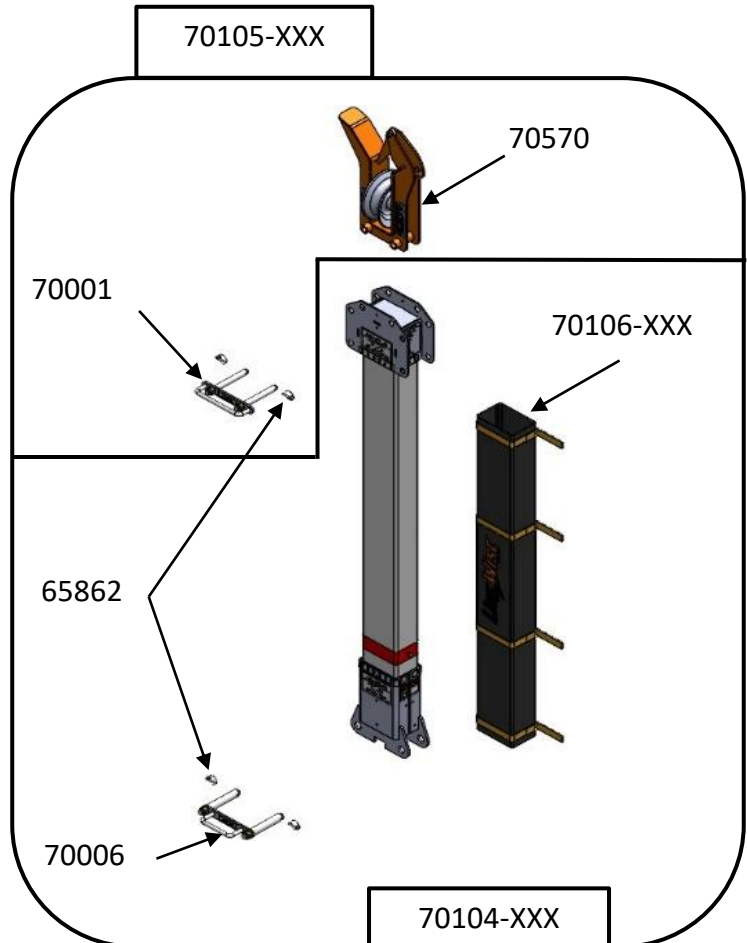

Continued on next Page

6

Available Options

Continued from page 3

QTY: ___ 3.5' Static Extender (72350-042)

QTY: ___ 5' Static Extender (72350-060)

QTY: ___ Adjustable Static Arm (73578) (must add Insulator)

QTY: ___ 2-3' Extending Wire Holder Arm (73819)

QTY: ___ Delta Wire Holder (72641)

QTY: ___ Vertical Bundle Lifter (72998) (10.00" Spacing)

QTY: ___ 2' Boom Span Extender (73160)

QTY: ___ 1' Insulator Boom Span Extender / Shortener (73549)

QTY: ___ Desiccant (30046-009) (5 LB Jug) Not Shown

QTY: ___ Extra Remote (74692-01) Not shown

QTY: ___ Solar Charger Kit (75100) (One included with unit produced after 03/2023. Older units can be retrofitted.)

QTY: ___ Trailer 20'-24' x 102" (GVWR 14K) (74022)

QTY: ___ Storage Container (73580) See Engineering for configuration number

QTY: ___ Skid Cover (73705) without Vinyl

PO #:

Signature:

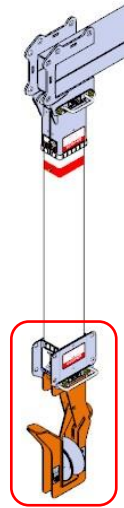

72641

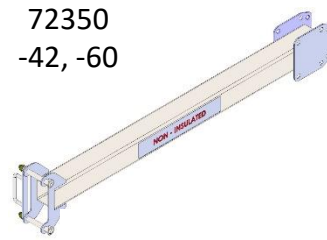

72350
-42, -60

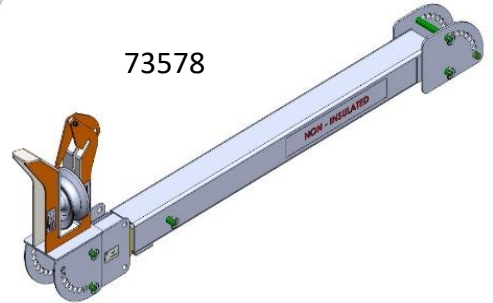

73578



72998

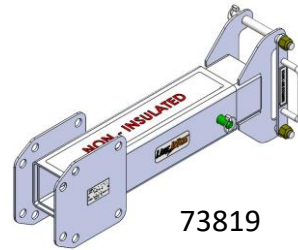

73819

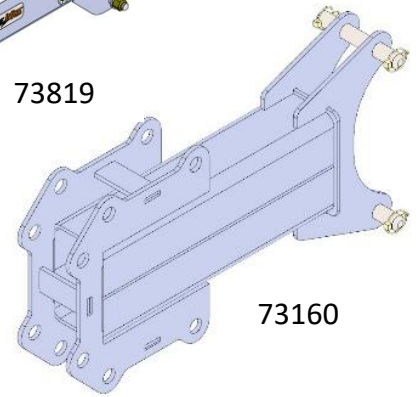

73160

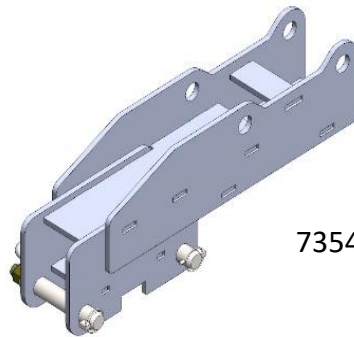

73549



75100

74022



73580

