

**The Triple Line Lifter-6000 is an insulated crane attachment used to support up to three energized lines.**

**The TLL-6000**

- Maximum capacity of 6000 pounds (2722 kg) per phase with a total capacity of 18000 pounds (8165 kg).
- Own or lease a unit and use it on your own schedule.
- Faster set up time.
- Radio remote provides the crew in the bucket with complete control of the unit's functions and avoids having to relay desired movements to ground personnel working the controls.
- Ability to capture phases and neutrals/statics with the same crane. Reducing the equipment needed at a job site and further eliminates shutdown of transmission lines for maintenance.
- One base unit can fit multiple crane models with additional adapters and load charts.



**FEATURES**

- Hydraulic articulation, extension & retraction
- Quick attach insulators & wire holders
- Insulators are dielectrically lab tested (retest every 2 years)
- Operation, Maintenance and Parts manuals
- Custom range diagrams for your crane model(s)
- Vertical and horizontal line construction
- High strength steel and fiberglass fabrication
- Holding valves on all cylinders
- Manual override control valves
- Handheld radio remote control

**Hydraulic Power Unit**

- 3000 psi (20684 kPa) and 15 gpm (57 l/min)
- Hose reel with power return
- Gasoline engine 40HP (29828 watts)/ electric start
- 130' (39624 mm) of nonconductive hose (2)
- Fork pockets, 4 lifting rings with rigging



**Transportation Trailer**

- Lift rigging and down points
- Racks for:
  - Insulators, wire holders & pins
- 4 corner jacks to level skid to crane
- Steps/handrails to access boom tip for installation
- Tilt to raise unit to pin to crane

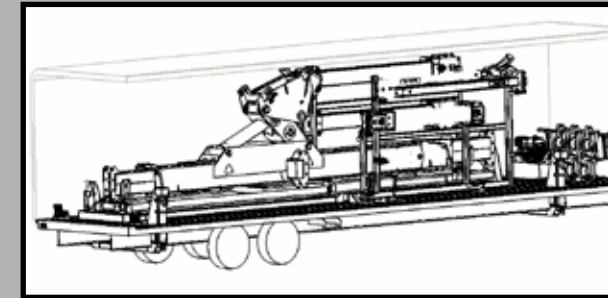

**SPECIFICATIONS**

Voltage (#) Phases 400 kV (3) phases	Capacity per position 6000 lb (2722 kg)/18000 (8165 kg) total
Total unit weight (Approx.) TLL-6000 TLL-6000 w/(1) static arm TLL-6000 w/(2) static arms	14000 lb (6350 kg) 14650 lb (6645 kg) 15300 lb (6940 kg)
Max. Phase Spacing Outside to Outside Center to Outside	62' (18898 mm) 31' (9449 mm)
Min. Phase Spacing Outside to Outside Center to Outside	32' (9754 mm) 16' (4877 mm)
Horizontal Configuration Max Load per Position	6000 lb (2722 kg) vertical load 1500 lb (680 kg) side load
Vertical Configuration Max Load per Position	6000 lb (2722 kg) vertical load 1500 lb (680 kg) side load
Maximum Load per Static Arm Wire Holder	600 lb (272 kg) vertical load 250 lb (113 kg) side load
Insulator Type	Fiberglass, sealed with desiccant system
Hydraulic Articulation	Yes
Crane Size Needed	Minimum 300 Ton Crane

**CONFIGURATIONS**

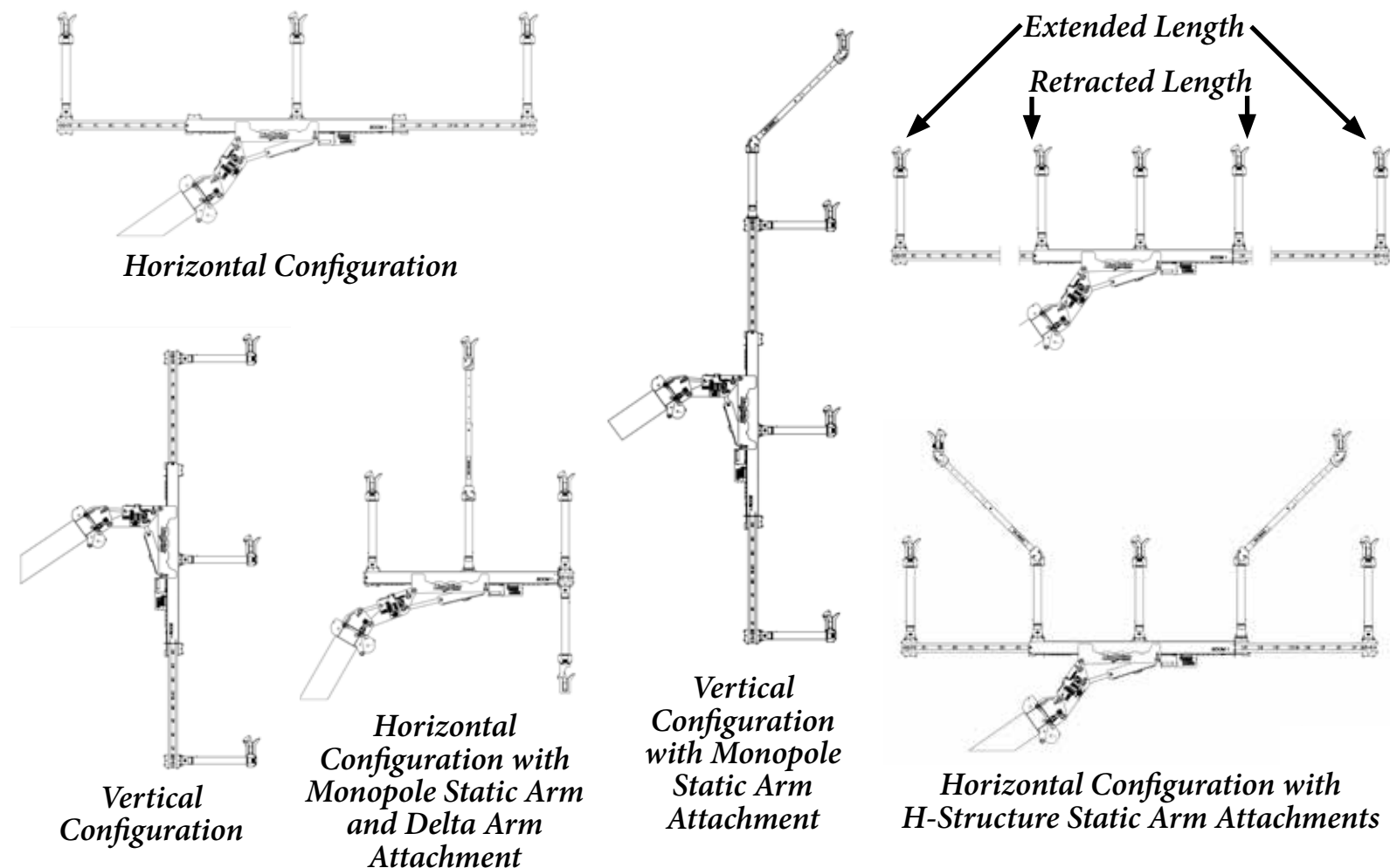

# OPTIONS

- Adapters made for specific cranes
- Adjustable static arms for vertical or horizontal configuration
- Swing gate wire holders
- Vertical/horizontal bundle wire holders
- Product operational by hydraulics
- Storage box for additional insulators
- Fully covered skid on trailer

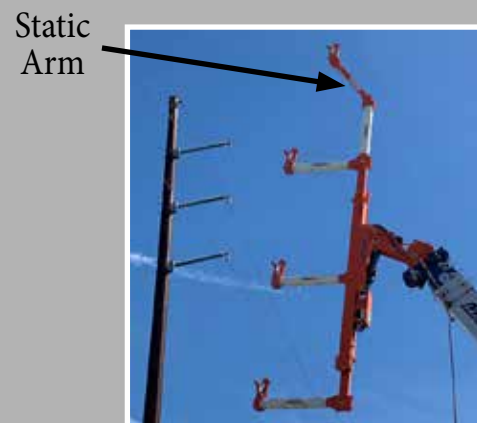

Swing Gate Wire Holder

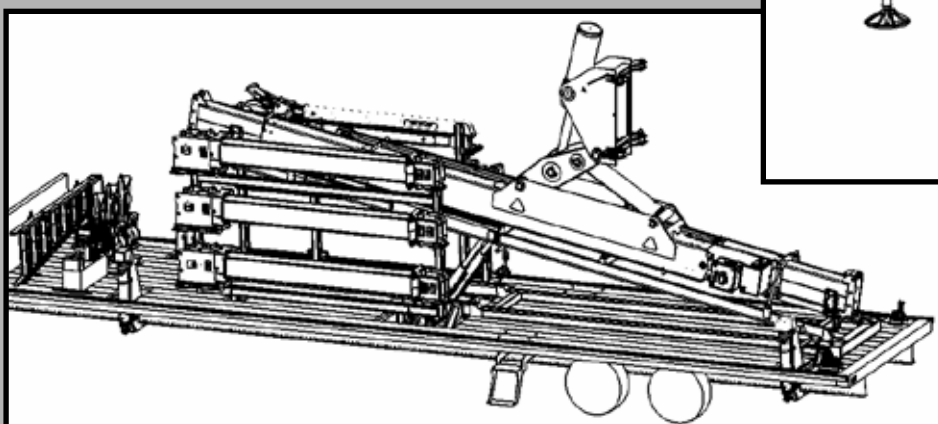
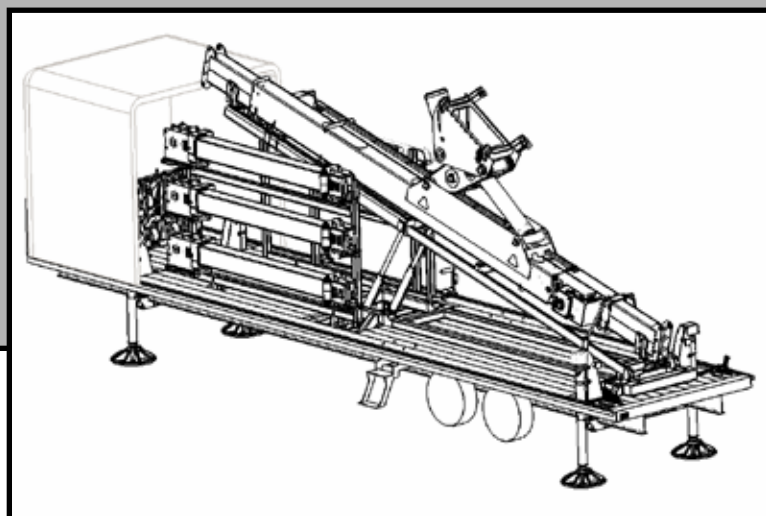

**INSPIRED,  
TESTED,  
AND TRUSTED  
BY LINeworkERS**



**LINEWISE**

Triple Line Lifter-6000



Material and specifications are subject to change without notice. Units in photos may include optional features. Contact a LineWise representative for available options. LineWise® and the LineWise logo are registered trademarks of Fritel & Associates, LLC and may not be used without permission.  
© 2025 Diversified Product Development All Rights Reserved.