

The TLL-500A-S1 & 2 is an insulated crane/digger derrick attachment used to support up to three energized lines.

The TLL-500A-S1 & 2

- Maximum capacity of 500 pounds per phase for a total capacity of 1500 pounds.
- Faster set up time.
- Ability to capture phases and neutrals/statics with the same crane/digger derrick. Reducing the equipment needed at a job site and further eliminates shutdown of sub-transmission lines for maintenance.
- One base unit can fit multiple crane/digger derrick models with additional adapters and load charts.
- Skid stores all components on unit. Components are pinned to the structure and placed in order of assembly.



FEATURES

- Quick attach insulators & wire holders
- Insulators are lab tested
- Mast turntable allows for 15° swivel left or right when the TLL-500A is in line with the crane boom or perpendicular.
- Operation, Maintenance and Parts manual included
- Custom load charts for your crane/digger derrick model(s)
- Vertical and horizontal line construction
- High strength steel fabrication
- Installed at ground level

Transportation Skid

- Stores all the components of the unit
 - Adapter, Insulators, wire holders & pins
- Components are pinned to the structure of the skid.
- Components are placed in order of assembly to make building/tearing down the unit easier.

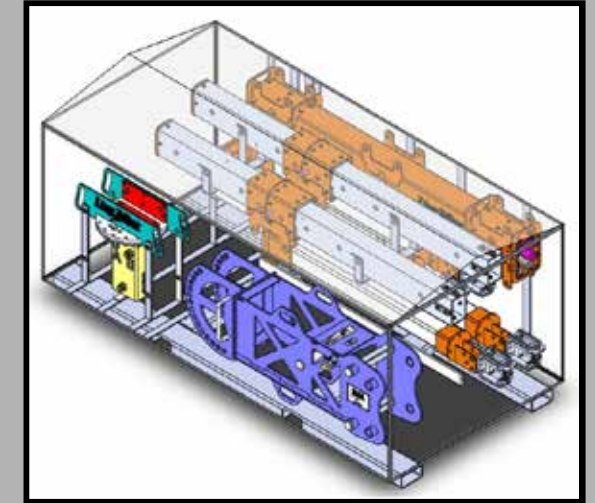

SPECIFICATIONS

Voltage (#) Phases 34.5 kV (3) phases 72.5 kV (3) phases	Capacity per phase 500 lb (225 kg)/1500 (680 kg) total 500 lb (225 kg)/1500 (680 kg) total
Total unit weight (Approx.) TLL-500A with skid TLL-500A w/o skid	1650 lb (748 kg) 700 lb (317 kg)
Max. Phase Spacing Outside to Outside Center to Outside	16' (4877 mm) 8' (2438 mm)
Min. Phase Spacing Outside to Outside Center to Outside	5' (1524 mm) 2' 6" (762 mm)
Maximum Horizontal Load per Phase	500 lb (225 kg) 300 lb (136 kg) on Altec Digger
Maximum Vertical Load per Phase	500 lb (225 kg) 300 lb (136 kg) on Altec Digger
Insulator	Polymer
Hydraulic	No
Mounting	Crane/Digger Derrick

COMPONENTS

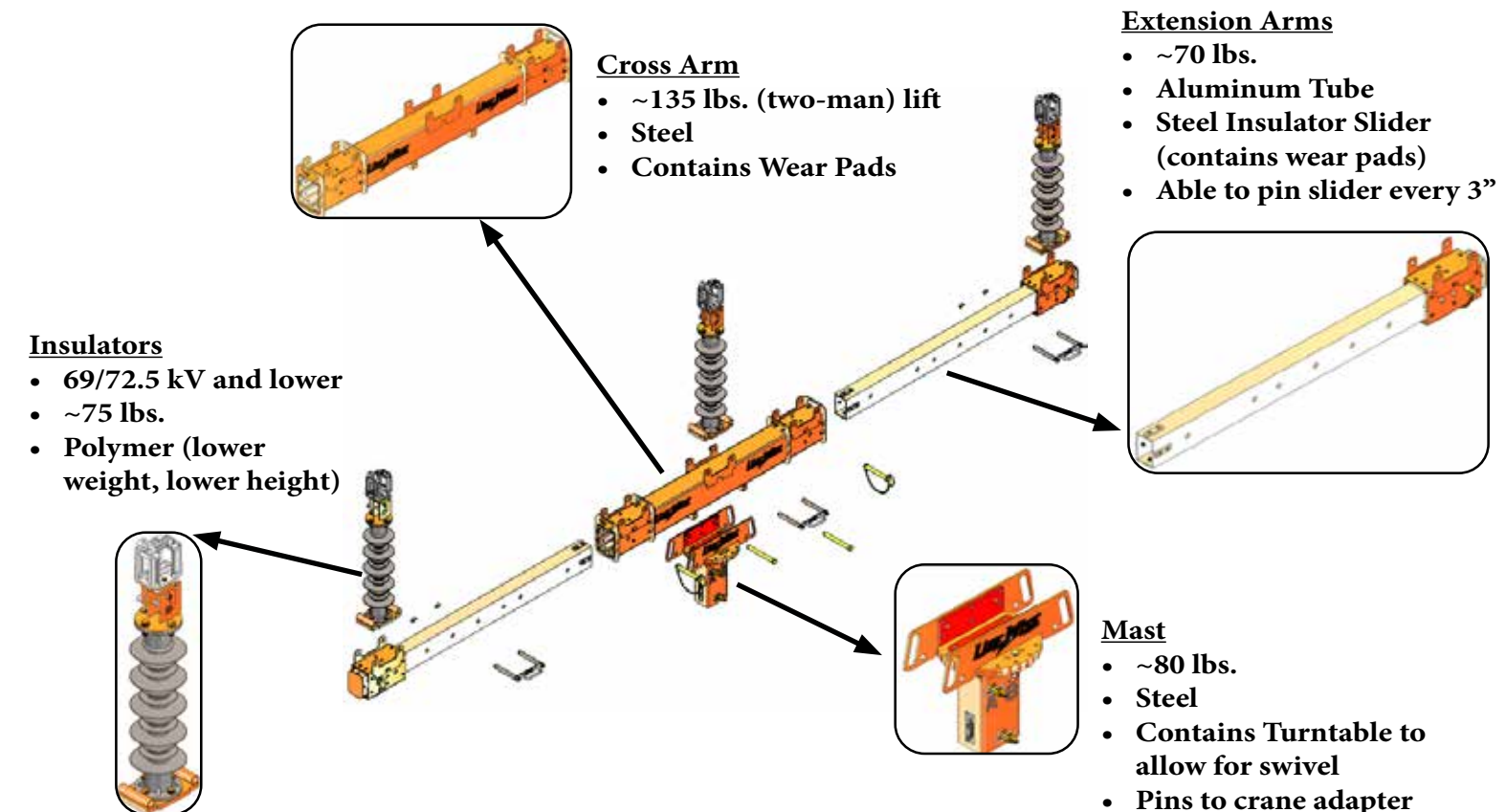

OPTIONS

- Adapter to use with different crane
- 34.5kV/72.5kV Polymer Insulators
- Fully covered skid
- Field installation and training with every unit

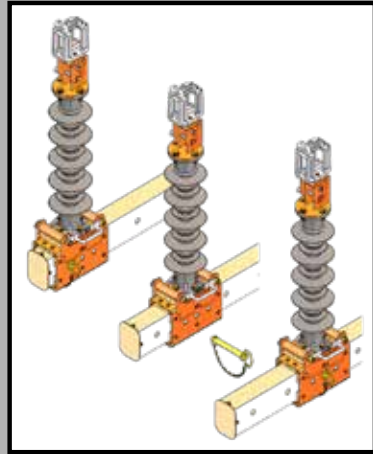

TLL-500A Series 1

- Insulator sliders can manually pin every 3"

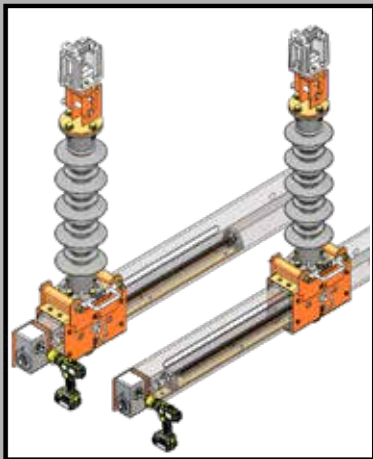

TLL-500A Series 2

- Insulator sliders are adjusted with a lead screw assembly by applying torque from an impact driver



Polymer Insulators

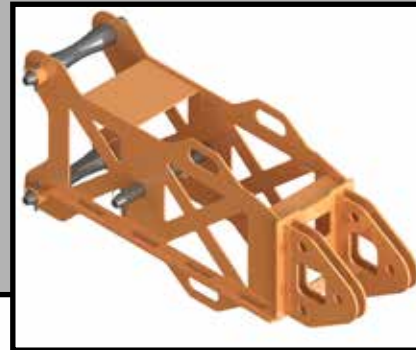

Adapters



LINEWISE

Triple Line Lifter-500A-Series 1&2



INSPIRED BY LINEMEN TESTED BY LINEMEN TRUSTED BY LINEMEN

Material and specifications are subject to change without notice. Units in photos may include optional features. Contact a LineWise representative for available options. LineWise® and the LineWise logo are registered trademarks of Fritel & Associates, LLC and may not be used without permission. © 2022 Diversified Product Development All Rights Reserved.